

Products for Chromatography

Hydrogen Generators for Fuel Gas



Model H2PEM Hydrogen Generator with Agilent 7890 GC-FID

Features and Benefits

- Ideal for fuel gas, up to 14 FIDs
- Eliminates dangerous and expensive hydrogen gas cylinders from the laboratory
- Exclusive water management system and control circuitry maximize uptime
- Unique display lighting changes color for easy status checks and water level indication
- Remote control and remote monitoring capable by adding USB options bay controller
- Certified for laboratory use by CSA, UL, cUL, and CE Mark
- Compact and reliable - only one square foot of bench space required
- Uses no liquid caustics

Parker Balston's Proton Exchange Membrane (PEM) Cell eliminates the use of liquid electrolytes with hydrogen generators.

Proven in over 40,000 GC installations worldwide. Parker Balston's generators are the most reliable hydrogen generators on the market. Maintenance requires only a few moments per year - no inconvenient, extended downtime.

Simply change the filters every six months, the desiccant cartridge whenever it turns from beige to clear, and the hydration pump biannually.

Deionized water is all that is required to generate hydrogen for weeks of continuous operation.

With an output capacity of up to 510 cc/minute, one generator can supply 99.9995% pure hydrogen for up to several FID's. Based on cylinder gas savings alone, a Parker Balston® hydrogen generator pays for itself in one or two years.

All Parker Balston® hydrogen generators meet NFPA requirements and OSHA 1910.103 regulations governing the storage of hydrogen.

Produced and supported by an ISO 9001 registered organization, Parker Balston's hydrogen generators are the first built to meet the toughest laboratory standards in the world: CSA, UL, cUL, and CE Mark.

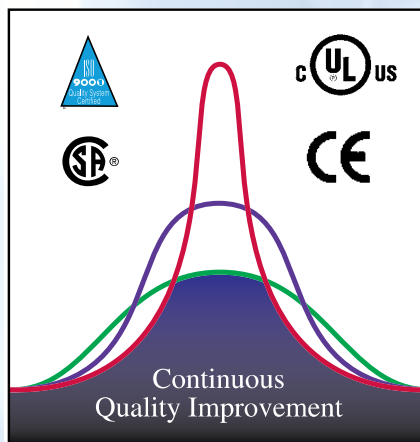

Products for Chromatography

Hydrogen Generators for Fuel Gas

Principal Specifications

Model Number	H2PEM-100	H2PEM-165	H2PEM-260	H2PEM-510
Purity	99.9995%	99.9995%	99.9995%	99.9995%
Flow Rates	100 cc/min	165 cc/min	260 cc/min	510 cc/min
Outlet Port	1/8" compression	1/8" compression	1/8" compression	1/8" compression
Electrical	100-230Vac/50-60Hz	100-230Vac/50-60Hz	100-230Vac/50-60Hz	100-230Vac/50-60Hz
Delivery Pressure	10-100 psig \pm 1 psig	10-100 psig \pm 1 psig	10-100 psig \pm 1 psig	10-100 psig \pm 1 psig
Shipping Weight	40 lb (18 kg) dry	40 lb (18 kg) dry	40 lb (18 kg) dry	40 lb (18 kg) dry
Dimensions	17.12"H x 13.46"W x 17.95"D (43.48cm x 34.19cm x 45.6cm)	17.12"H x 13.46"W x 17.95"D (43.48cm x 34.19cm x 45.6cm)	17.12"H x 13.46"W x 17.95"D (43.48cm x 34.19cm x 45.6cm)	17.12"H x 13.46"W x 17.95"D (43.48cm x 34.19cm x 45.6cm)

Ordering Information for assistance, call 800-343-4048, 8 to 5 Eastern Time

Model	Description
MKH2PEM-D	Dessicant cartridge (1 each)
MKH2PEM-6M	6 Month Service Kit
MKH2PEM-24M	24 Month Service Kit
H2PEM-PM	Preventative Maintenance Contract

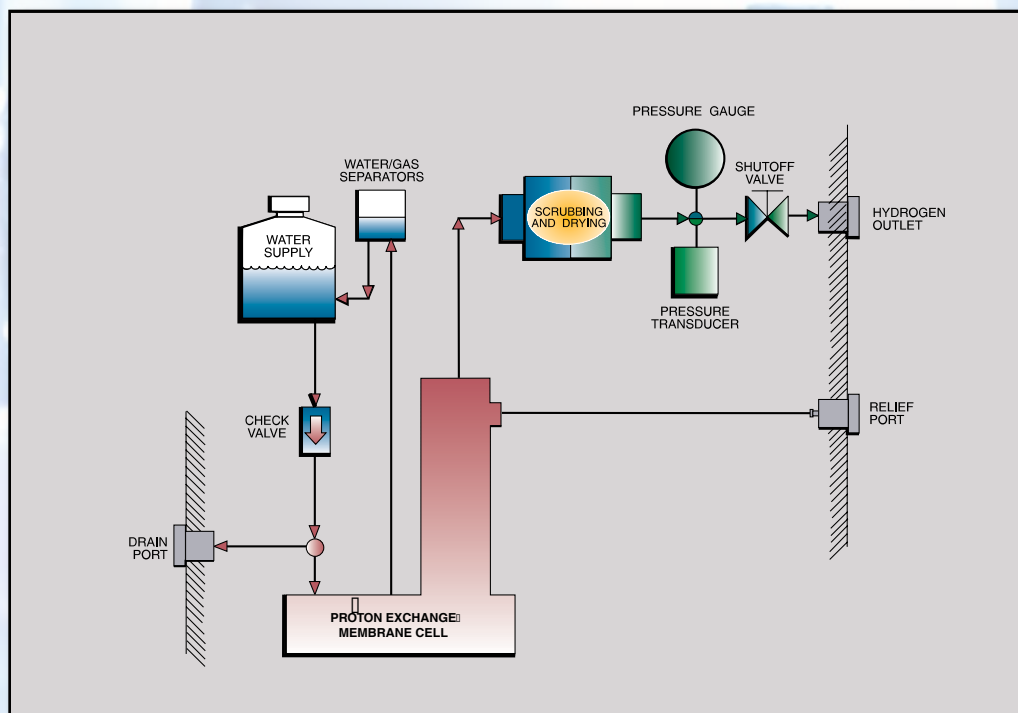

Hydrogen Technology



Filtration & Separation Division
 Distributed By:
 Chrom Tech, Inc.
 Tel: 800-822-5242
 Fax: 952-431-63451
 www.chromtech.com